

Natural Lawn Care

Division of Plant Sciences



Photo: Jeff Zimmerschied

Increasing numbers of homeowners are inquiring about low-impact environmental approaches to lawn care. This has generated many questions and concerns from lawn care operators and turf managers. Using natural or environmentally friendly products seems to be the direction many are taking to maintain their lawns.

Historically, before managers had an extensive list of chemicals to choose from, keeping turfgrasses healthy was the best defense against weeds, diseases and insects. Soil fertility and organic matter were considered especially important. Early publications emphasized healthy plants as an important aspect of pest prevention. In time, increasing demand for higher quality lawns led to unsustainable management practices. What was once the norm (sustainable practices) has since become the alternative method of lawn care. However, with growing awareness of environmental issues associated with current practices, many turf managers are starting to reconsider this approach to turfgrass maintenance, especially in sports turf, parks and recreation areas. Lawn care operators are seeing

increased interest from clientele for organic solutions. In many areas, new regulations in the lawn care industry are causing shifts in the types and amounts of products available for home lawns. With interest on the rise, one frequently asked question will be, "What can one expect from a natural lawn care program?"

Philosophy of natural lawn care

Soils are the foundation for a healthy lawn; they are a living, dynamic, biologically active resource that provides nutrients, water and oxygen to your lawn. Natural lawn care promotes the life and health of your soil. Several natural lawn care products add proteins that are beneficial to the soil microbes. Through a combination of specific products and cultural practices, a natural lawn care program promotes an optimal relationship between plants and soil.

Homeowners and clients need to understand that regardless of the type of care a lawn receives, there is no such thing as a perfect lawn. Lawns maintained with natural products can become stronger and healthier. In essence, all education about organic lawn care stresses the integration of good cultural or management practices. By going organic, you will rely more on lime, natural fertilizers and other natural products than on synthetic fertilizers and pesticides to correct a problem. It does not necessarily mean you will never resort to synthetic products; but you will use smaller quantities of these products and only when needed. You may need to use synthetic pesticides occasionally on organic lawns to correct a large problem or spot-

Authors

Brad Fresenburg and **Travis Teuton**, University of Missouri Turfgrass Research Center, Division of Plant Sciences

Don Day, Natural Resource Engineer, MU Extension, Central Missouri Region

Jeff Zimmerschied, The Lawn Company, Columbia, Mo.

treat a smaller problem. Through use of natural products and good cultural practices, natural lawn care can reduce your total inputs for lawn maintenance and contribute to improved water quality in your community. So it is important to learn what works and how to go about it.

This publication provides an introduction to natural lawn care but by no means covers the subject completely. Two thoughts run through this guide: (1) Natural lawn care depends on a healthy soil with good amounts of organic matter and a large population of active soil organisms; and (2) Simple steps are best. Measuring your lawn and soil testing are the first steps. Then simply follow good cultural practices and incorporate key organic fertilizers or minerals. Other beneficial products can be added based on your soil test or problems that need correction.

Measuring your lawn

Area measurements and mapping a lawn should be the first step in any home lawn care program. It is essential to know the area of your lawn in square feet to make accurate applications of fertilizers and other lawn care products. The most commonly used units of measure for turfgrass area are acres and square feet. Most home lawns can be measured in units of 1,000 square feet.

Calculating the area of an odd-shaped lawn can be accomplished by breaking it down into simple geometric figures as follows (see Figure 1).

	Geometric figures:
Rectangle	Area = length × width
Triangle	Area = (length of base × height) / 2
Circle	Area = 3.14 (radius)²

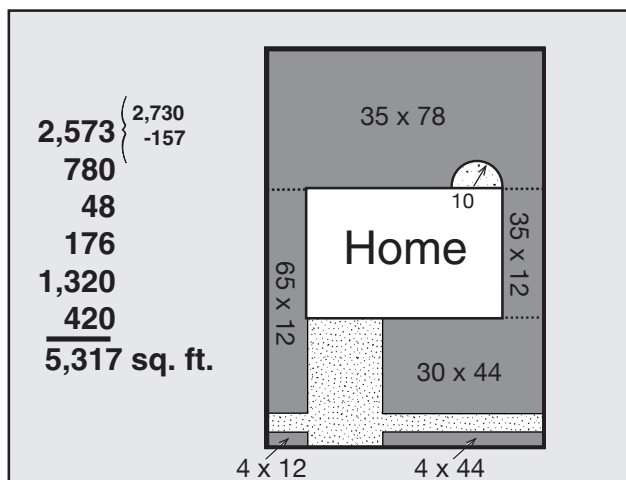

Figure 1. The area of this lawn can be calculated as the sum of the areas of six rectangles, minus the area of a semicircle.

Applying the right amount of product

Accurate applications of fertilizers and lawn care products are important to the health of your plants and to the quality of the environment. Applying too much

synthetic fertilizer or pesticide to your lawn can cause foliar burns and injury or have negative environmental effects. While applying too much of a natural lawn care product is usually not injurious to your lawn, it can be economically infeasible. Applying too little of fertilizers or lawn care products can result in a low-quality lawn that is deficient in what it needs and prone to pest problems.

The only way to know how much fertilizer or lawn care product is being applied to your lawn is to calibrate your application equipment. Calibration begins with knowing the total area of your lawn and making sure you apply the correct amount of material for that area as recommended by the manufacturer. Always read and follow the product label.

Homeowners have a wide variety of spreaders to work with, including drop-type spreaders, rotary spreaders, some spreaders that are listed on the product label and many that are not (Figure 2). Rotary spreaders are the best option for applying lawn care products. They make applications easier because you do not need to worry about coming back precisely on your previous wheel marks. Rotary spreaders also

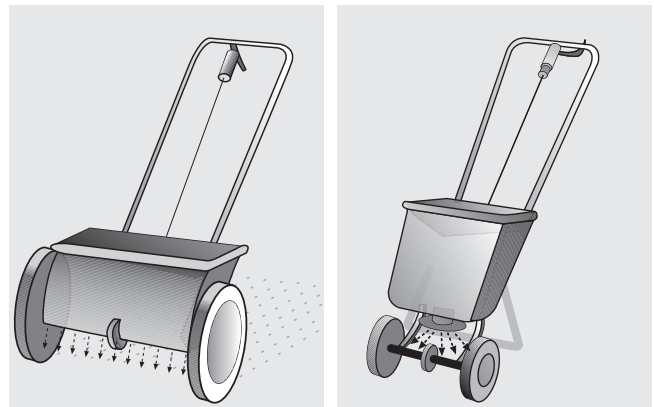

Figure 2. Two common types of fertilizer spreaders are drop spreaders (left) and rotary spreaders (right).

require fewer passes to cover your lawn.

The best approach for homeowners does not necessarily require the actual calibration of a spreader, but rather a more common sense approach to applying lawn care products. First, you need an accurate measurement of the area of your lawn so that you can purchase the correct amount of lawn care product. For example, if your lawn measures 10,000 square feet and the lawn care product label states that the contents of one bag cover 5,000 square feet, you need two bags of this product to cover your lawn. Second, you need to distribute that material evenly over the total area of the lawn. Even distribution is usually assured with multiple passes in different directions over your lawn. Therefore, place your spreader on a light setting and continue to make passes over your lawn, changing directions with each pass until all the required material has been applied. This may require several trips over

your lawn, but you can be certain that the distribution of the material is uniform. In time, as you become familiar with your spreader and the products you use; you can fine-tune your spreader to reduce the number of trips required.

Most fertilizer and lawn care product packaging includes tables with suggested settings for various brands of spreaders. Keep in mind that those settings are usually for one pass over the lawn. These application tables also assume a 3-mile-per-hour walking speed. To give uniform applications, consider cutting the setting by half to one-third, making two to three applications to avoid skips.

Soils and fertility

Soil biology

Weed, disease and insect problems and poor turfgrass performance are often symptoms of an incomplete or deficient soil system. Pests are typically kept in check with pesticides, and poor turfgrass performance is routinely dealt with by adding more synthetic fertilizers and additional water. But the underlying problem may be related to either biological or abiotic (nonliving) components of that soil, or a combination of both.

Turf is healthiest in a biologically balanced soil — one in which bacteria account for slightly more than half of the biomass. Bacteria thrive in soils that contain residues high in carbohydrates, such as sugars and starches. Organic fertilizers such as vegetable and animal meals and compost made from food waste or manure contain the carbohydrates necessary to sustain a bacteria-dominated soil.

Applying carbohydrates and proteins, ingredients usually not included in many synthetic fertilizers, is part of a “feed the soil” philosophy. Maintaining a balanced, healthy soil system ensures that the essential nutrients we apply are used efficiently (Figure 3).



Figure 3. An excellent indicator of a healthy soil is the existence of earthworms or earthworm castings.

Soil testing

Before applying fertilizer or lime, you have to identify deficiencies in your soil. A routine soil fertility test (pH, neutralizable acidity, phosphorus, potassium, calcium, magnesium, organic matter and cation exchange capacity) is recommended under the following circumstances:

- Before establishing a new lawn, whether from seed, sod or sprigs.
- Every three years on established lawns (early spring or early fall).
- Annually to correct a nutrient deficiency or change the soil pH.

Taking a soil sample:

- Your local MU Extension center has soil sample boxes available for use at no charge. One box (1.5 to 2 cups) is all the University lab needs for analysis. A brown paper lunch bag will also work.
- Using a small shovel or soil probe, sample to a depth of 4 inches on established lawns or before seeding.
- Take 12 or more random cores from each area of the lawn to be tested and remove the thatch and live plant material before breaking up the cores and mixing thoroughly in a clean, dry plastic bucket. (Metal buckets contaminate the sample with micronutrients.) Take random samples from the lawn as a whole unless there is a need to sample problem areas separately.
- Obtain a Horticulture Soil Sample Information form, MP 555, from your local MU Extension center or from the Web (MU publication G6954, *Soil Testing for Lawns*). Take the soil sample to your local extension center (find an office on the Web at extension.missouri.edu/regions) or send the sample to the following address:

Soil and Plant Testing Laboratory
23 Mumford Hall
University of Missouri
Columbia, MO 65211

Additional note to soil testing:

Minerals are best applied in the spring or fall according to soil test results. However, applications of minerals will help many soils regardless of soil testing. Interpretations of soil test results may not always be clear, and you may require the advice of your local extension office.

Calcium and magnesium

Calcium (Ca) helps give plants structural rigidity, which is extremely important in trafficked areas. Calcium also regulates root and shoot growth and the development of several important enzymes.

Magnesium (Mg) functions as a crucial component

of chlorophyll, activates many essential enzymes and plays a role in protein synthesis. Consistent availability of calcium and magnesium is critical to the health of turf plants.

Calcium and magnesium can be added to the soil by liming, which naturally releases ions into the soil solution at a relatively slow and sustained rate. This release rate is typically more effective and efficient in a biologically active soil system. Having a constant and adequate supply of nutrients available to turf plants is important and difficult to accomplish without sufficient exchange capacity in the soil. Without adequate storage capabilities in the soil (exchange capacity), shortages can occur that may trigger symptoms not necessarily indicative of a nutrient deficiency. Regular applications of compost teas (see below) can slowly build an exchange mechanism in the soil.

Soil pH can be adjusted with lime (to raise pH) or sulfur (to lower pH). Most plants consume significantly more calcium than they do magnesium, reducing the soil's supply of calcium at a much faster rate. Dolomitic lime (a readily available form of lime in Missouri) has a calcium-to-magnesium ratio of approximately 2-to-1. Over time, dolomitic lime can then cause an undesirable buildup of magnesium in our soils and should be avoided. Therefore, your best approach to adjusting soil pH is to use calcium carbonate lime (pelletized), available in 40- to 50-pound bags. The most important application for sulfur is to lower soil pH when needed.

Nitrogen

Plants use nitrogen (N) for many functions. Without nitrogen, plants cannot make amino acids, proteins, enzymes, chlorophyll or nucleic acids. These components are essential for plants to grow and function properly.

Applying the correct amount of nitrogen is important, but almost impossible to determine because a plant's daily needs fluctuate. The optimal amount of nitrogen today could be excessive or inadequate tomorrow. The peaks and valleys of nitrogen availability typical of many synthetic fertilizer programs cause the plant to react in several ways. When nitrogen is inadequate, plants elongate roots. When nitrogen is excessive, plants absorb far more than they need, causing excess succulent growth that increases the potential for disease and insects. In a balanced soil, mechanisms exist to buffer and regulate the amount of nitrogen available to plants.

Applications of compost or natural organic fertilizers complement the functions of soil organisms, and they, in turn, regulate the amount of nitrogen available to plants. This is not to say that soluble nitrogen should never be used, but if it is the only source of nitrogen applied, soil microbe activity is likely to be suppressed to a point where nutrient regulation is inadequate.

Phosphorus

Phosphorus (P) is a nutrient that plant roots can have a hard time finding without the help of soil organisms. Many turfgrass experts believe that established grass does not need a lot of phosphorus because it is used mainly for germination, flowering, seed production and initial root development. Phosphorus is, however, an extremely important element for turf plants and all other living organisms.

Most soils contain adequate levels of phosphorus for plants, but little may be available if soil organisms are relatively inactive. Availability of phosphorus, along with many other nutrients, increases when organic residues are introduced into the soil and the total amount available exceeds the amount of phosphorus contained in the residues alone.

Potassium

Potassium (K) is an extremely important nutrient for turf, especially if the plants have to endure many summer stresses — both natural (heat and drought) and man-made (traffic). Potassium gives plants the strength to stand upright and is often credited with disease resistance.

Most soils contain large amounts of naturally occurring potassium, but the vast majority of that potassium is bound to soil particles and organic matter and is unavailable to plants. Some of this bound potassium can, like phosphorus, be released through the activities of soil organisms.

Avoid using muriated potash (potassium chloride) as it increases the salt content of the soil. Sulfate of potash is the recommended source for potassium.

Biostimulants

Biostimulants typically contain amino acids, humic and fulvic acid or other stimulants that may enhance the action of plants' own hormones. Biostimulants can be applied as needed to help correct minor problems related to levels of organic matter as determined by a soil test. Annual applications of biostimulants will not harm your lawn, and may improve it.

Organic fertilizer sources

The amount of fertilizer applied to any lawn depends on soil type and characteristics, such as pH, organic matter content and cation exchange capacity. In new housing developments where top soils have been removed, low levels of organic matter and essential nutrients make lawn maintenance a challenge. It is in these situations where more of all soil nutrients (organic fertilizers, minerals, plant proteins, compost teas) is needed to return these soils to a healthy, biologically active condition. Table 1 lists various types of organic fertilizers that can be used to supply nutrients. Table 2 lists various sources of minerals. Table 3 provides a list of biostimulants.

Table 1. Organic fertilizer sources.

Material / product	N (%)	P ₂ O ₅ (%)	K ₂ O (%)	Other nutrients (%)
Bat guano	10	3	1	
Blood meal	13	0	0	
Bradfield (alfalfa pellets)	3	1	5	
Earthworks	5	4	5	Ca (3), S (2)
Earthworks	10	2	5	Ca (6)
Milorganite	6	2	0	Ca (1.2), Fe (4)
Nature Safe	10	8	5	Ca (1.8), S (3)
Organica Lawn Booster ¹	8	1	1	Ca (1)
Organica Plus	8	2	4	Ca (5), Mg (2), S (1)
Richlawn	6	3	2	
Ringer Lawn Restore	6	1	3	
Sustane	5	2	4	S (2), Fe (5)
Worm castings ²	0.86	0.37	0.25	Ca (2.3), Fe (0.72)

Notes:

1. contains corn gluten
2. Used to make compost teas or to sprinkle as a spot treatment on thinned turfgrass.

Table 2. Mineral sources.

Material / product	N (%)	P ₂ O ₅ (%)	K ₂ O (%)	Other nutrients (%)
Calcium carbonate				Ca (40)
Cal-Phos	0	3	0	Ca (20), trace minerals
Greensand	0	0	6	
Gypsum				Ca (22), S (16)
Planters II Trace Mineral	0	0.003	0.007	Ca (5), Mg (0.5), Fe (0.4), S(5)
Sulfate of potash	0	0	52	S (17)
Sulfur (granular)				S (90)
Sul-Po-Mag/K-Mag	0	0	22	Mg (18), S (22)

Table 3. Biostimulants.

Material / product	N (%)	P ₂ O ₅ (%)	K ₂ O (%)	Other nutrients (%)
Bov-a-mura (liquid)	5	0	0	Manure extracts
EarthWorks Kick				Humic acid, sea kelp, chelated Fe, invert sugars, microbes, wetting agent
Focus (liquid or granular)	7		6	Fe (1.4), humic and fulvic acid, kelp extract
Mosquito Barrier				Garlic juice (99), trace minerals
Launch (liquid or granular)			1	Fe (.36), manure extract, humic and fulvic acid, kelp extract
Mushroom Stuff				Fermented mushrooms, soil conditioners, micronutrients, vitamins, enzymes
Organica Agroroots	0.3	1.5	0.7	Kelp extract, micro-nutrients, cytokinins, vitamins
Organica Lawn Booster	8	1	1	Ca (1), 10 microbes
Organica Plant Growth Activator Plus (PGA+)				Seaweed, humic acid, 54 microbes

Fertilizer application schedules

Tables 4 and 5 provide standard application schedules for cool- and warm-season grasses. If you have special requirements for nutrients, choose a product from Tables 1 or 2 that best fits your situation to correct those deficiencies.

Table 4. Cool-season grasses: Application schedule for organic fertilizers.¹

	Early April	Late June	Mid-September
Most beneficial program No fall seeding	Corn gluten ² 0.8 – 1.2	Corn gluten ² 0.4 – 0.8	Corn gluten ² 0.8
Maintenance program Fall seeding	Corn gluten 0.8 – 1.2	Corn gluten or other organic product 0.4 – 0.8	Do not use corn gluten.³ Use other organic product 0.3 – 0.8

Notes:

1. Rates are expressed in pounds of nitrogen per 1,000 sq. ft.
2. Corn gluten-based organic products offer some preemergence weed control for annual weeds and can affect turfgrass seed germination. Be sure to purchase corn gluten products that are in a granular formulation. They are much easier to spread.
3. Avoid the use of corn gluten in mid-September when overseeding. However, corn gluten can be applied after seedlings have emerged and reach a height of 1.5 inches.

Table 5. Warm-season grasses: Application schedule for organic fertilizers.¹

	Mid-April	Late June	Mid-August
Most beneficial program	Corn gluten ² 0.8 – 1.2	Corn gluten ² 0.4 – 0.8	Corn gluten ² 0.8
Maintenance program	Corn gluten 0.8 – 1.2	Corn gluten or other organic product 0.4 – 0.8	Corn gluten or other organic product 0.3 – 0.8

Notes:

1. Rates are expressed in pounds of nitrogen per 1,000 sq. ft.
2. Corn gluten based organic products offer some preemergence weed control for annual weeds and can affect turfgrass seed germination. Be sure to purchase corn gluten products that are in a granular formulation. They are much easier to spread.

Important cultural practices

Selecting turfgrass species and cultivars

Blends of turf-type tall fescues or a mixture of tall fescues with a small amount of Kentucky bluegrass are recommended choices for cool-season grasses in Missouri (See Overseeding section below for rates and ratios). Some diseases can be completely avoided by selecting grass species that are not susceptible to certain pathogens. For example, summer patch is a severe problem on Kentucky bluegrass but has little effect on tall fescue. An area historically prone to summer patch disease can be planted to tall fescue to reduce that potential. Likewise, within species of grasses, selected varieties can offer more disease resistance than others. Varieties of Kentucky bluegrass may show

a higher level of tolerance to rust disease and perhaps be selected as part of a blend or mixture of seed. Even though these grasses are termed disease resistant, it does not mean that they are 100 percent disease free. Selecting varieties with higher disease resistance will reduce your potential for turfgrass diseases and becomes the first step in a line of cultural practices to manage turfgrass diseases.

As you consider reseeding or overseeding, also consider using endophyte-enhanced grass seed whenever available. Endophytes are fungal organisms that live symbiotically within the cells of the grass plant and reproduce during cell division. They create a bitter-tasting toxin that repels most insects and kills many of those that continue to feed. Many varieties of cool-season grasses contain endophyte, especially tall fescues. You can contact your local extension office for grass species and varieties that have been recommended for Missouri.

Mowing

Mowing is the most important, intensive cultural practice that lawns are subjected to over the growing season. Improper mowing puts turfgrasses under stress and increases their susceptibility to weeds, diseases and insects. Therefore, proper mowing practices such as a sharp blade and correct mowing height equals fewer inputs (less expense) for a homeowner or professional grounds manager.

Optimal cutting heights for cool-season grasses, such as blends of turf-type tall fescues, range from 3 to 4 inches, and Kentucky bluegrass should be mowed at heights from 2.5 to 3.5 inches. Cutting heights for warm-season grasses, like zoysia, can range between 1.5 and 2.5 inches. Refer to the mower operator's manual for information on setting the cutting height.

Seasonal variation in mowing height was once thought to be highly beneficial and is still considered beneficial by some. However, current recommendations are to select a single mowing height for the entire season. We know that mowing cool-season grasses a little taller in the summer months can have benefits through summer stress periods (deeper roots, better cooling effect). Taller grasses will also conserve moisture, somewhat reducing irrigation requirements. We also know that increasing the mowing heights in the spring and fall allows the turfgrass to compete more successfully against weeds (up to 80 percent control of annual weeds). Therefore, select the tallest, acceptable mowing height for your species of grass and maintain that height during the entire season. This provides benefits throughout the season by improving competition against weeds and reducing summer stress.

Clippings should be uniformly distributed rather than deposited in clumps. Mowing the lawn when the grass is dry and using a properly sharpened mower blade will spread clippings evenly. If some areas pro-

duce excess clippings, simply mulch those in with a second pass of the mower.

Mowing creates wounds through which fungi can enter the turfgrass plant and infect it. Leaf cuts made by a sharp mower blade are cleaner and heal faster than the tearing and shredding caused by a dull mower blade. A dull mower blade inflicts more and bigger wounds that increase the potential for infection by turfgrass diseases. Having a sharp, spare mower blade allows you to switch blades when needed and prevents delays in mowing when getting your mower blade sharpened. Always follow proper procedures for safe removal, replacement and sharpening of mower blades.

Observe freshly mowed leaf tips in your lawn or grass clippings collected on your mower deck immediately after a mowing to determine the quality of cut. Jagged edges where the leaf blades were cut by your mower indicate that the mower blade may be dull. Use this as an indicator of when to sharpen mower blades.

During hot summer months it is best to mow later in the day to minimize additional stresses on your grass. It is also best to change directions of mowing each time you mow.

Frequency of cut should be determined by the "one-third rule" of mowing. You should make sure that no more than one-third of the leaf growth is removed during a single mowing. During the spring, cool-season grasses can be mowed every five to six days. However, lawns maintained naturally will typically have four to five fewer mowings per season due to the uniform, controlled growth of a natural lawn.

MU publication G6959, "Don't Bag It" Lawn Care, describes how you can have a beautiful lawn without collecting your grass clippings. Observing the "one-third rule" as you mow will allow clippings to filter through the lawn canopy and decompose quickly. These grass clippings can return as much as 30 percent nitrogen and 50 percent potassium to the soil and will not contribute to the thatch level for tall fescue lawns. Grass clippings also contribute to the organic matter in your soil, improving the water- and nutrient-holding capacity of the soil. A soil rich with biologically active organic matter typically has fewer broadleaf weeds.

When is it OK to bag clippings?

When mowing is delayed because of rain.

When you wish to make compost. Refer to the following MU publications:

G6956, *Making and Using Compost*

G6958, *Grass Clippings, Compost and Mulch: Frequently Asked Questions*

When preparing for aeration and overseeding in late summer to early fall. Avoid using chemically treated grass clippings in compost.

A word of caution about weed trimming

Rotary line trimmers typically scalp turfgrasses when edging along sidewalks, curbs and driveways. This actually *promotes* weeds. Best edging practices include using a power edger or line trimmer (rotated) with a vertical blade to prevent scalping of turfgrasses.

Watering

Nearly all diseases require water for their development. Some disease problems such as pythium blight, brown patch and dollar spot are accentuated by extended periods of free moisture. In turfgrasses, such periods can be caused by dew, guttation fluids and frequent irrigation or rainfall. Guttation is the formation of water droplets containing exudates of sugars and proteins at the tips of grass leaves. These exudates serve as an excellent food source for diseases. Remove dew and guttation fluids from grass leaves by dragging a hose across the surface, using a whipping pole, or briefly irrigating only long enough to wash the dew from the surface. Following these methods will spread the concentrated dew or guttation over a larger surface area, causing the turf canopy to dry faster.

Improper irrigation alone may create a disease problem that could have been prevented. Avoid frequent irrigation that results in extended periods of free moisture. Avoid late evening watering that extends free moisture period throughout the night. Cool-season grasses can be allowed to have drying periods (near wilting) to disrupt the growth cycle of fungi. Cool-season grasses can go into a temporary state of survival (dormancy) when they do not receive water. Even though the lawn has a straw color, it is not dead. Only in extreme drought conditions will a lawn move beyond dormancy and into desiccation. Less water use and less mowing are advantages to a dormant lawn. Recovery will occur when adequate rainfall begins.

Irrigation in the early morning not only limits extended periods of dew and guttation (reducing disease potential), but irrigation is also applied at a time of day when temperatures are low (reducing evaporation) and winds are calm (for better distribution of water). A rule of thumb is to avoid puddles and runoff during irrigation, put the water where it is needed, and irrigate only what your particular soil type can absorb in one cycle. Lawns need 1 to 1.5 inches of water a week either from rainfall or from irrigation, if you choose to water on a weekly basis.

When checking moisture in the soil, use a screwdriver or pocketknife to dig a little soil from the surface. If the soil sticks to the screwdriver (or knife), you have sufficient soil moisture.

Soil aeration

Aeration is a practice of pulling soil plugs to open the soil surface for better movement of air, water and nutrients. It is a practice that also helps to reduce com-

paction and thatch (when it exists) by spreading soil plugs on the surface. Soil plugs are crumbled and fall freely into aeration holes as well as spreading some soil into the thatch layer where soil microbes can feed on thatch debris. Aeration on tightly compacted clay soils may be necessary twice a year initially (March and September). However, after several years of natural lawn care, it is usually sufficient to aerate the soil once a year (September) or even less frequently.

Aeration is the best way to begin a fall fertilization program. Applications of fertilizer after aeration will move nutrients immediately into the root zone of your lawn. This practice has shown excellent results in the density and color of cool-season turfgrasses on their way to recovery from summer stresses.

Aeration is also an excellent practice before fall overseeding. If lawns show some thinning from a stressful summer, overseeding is recommended to maintain the density desired for a quality lawn. Aeration prior to seeding will help ensure better seed/soil contact for improved germination.

Aeration equipment can be found at local rental stores or garden centers. Many lawn care providers also offer aeration services at a reasonable cost. A machine that pulls a half-inch-diameter plug 3 to 4 inches deep on 4-inch centers will do an excellent job. Machines that force hollow tines into the soil are better than pull-type drums with tines. Not all machines will meet these specifications. However, any amount of aeration is better than no aeration to kick off fall fertilization and overseeding. When using aeration equipment for fall overseeding, it is only necessary to penetrate the soil about an inch with multiple passes.

Thatch

Thatch problems are relatively rare in fescue lawns and in low-input or organically maintained turf because most of the inputs are as beneficial to soil organisms as they are to turf. Compost and organic fertilizers stimulate the biological activity needed to control thatch. Healthy soils generate large populations of organisms that consume thatch as fast as it is created. However, certain types of turfgrass species like Kentucky bluegrass and zoysiagrass are more prone to thatch development, and annual evaluations for thatch are necessary for these species to maintain a high-quality home lawn.

Overseeding

A thick lawn mowed tall (3.5 to 4 inches) provides the best natural weed control. Overseeding of cool-season grasses should occur in September to maintain the density required for competition against weeds. Lawns showing some thinning from summer stress can be overseeded with half the amount of seed used in a normal establishment or renovation. Normal seeding rates for turf-type tall fescue blends range from 7 to 9

pounds/1,000 square feet. Mixtures of tall fescue with Kentucky bluegrass in a 95-to-5 ratio should be seeded at the same rate for a normal seeding. Therefore, overseeding rates for these grasses should range between 3.5 to 4.5 pounds/1,000 square feet. As with fertilizers and other lawn products, applying seed at a half rate in two directions provides better distribution of the seed than applying all the seed in a single pass.

Keep in mind that it is always important to have good seed/soil contact for better seed germination. Covering seed with a light layer (¼ inch) of good quality compost is another way to help germination and improve the soil. When seeding small bare areas, avoid using straw because it contains weed seed. A good commercial mulch, such as PennMulch or Straw Net, is weed free and can be used instead.

Keep soil moist for several weeks until seed germinates. Light waterings (⅓ to ¼ inch) three to four times a day may be needed to keep soil surface from drying out and affecting seed germination.

Begin mowing as soon as grass reaches desired height (3 to 4 inches) to promote tillering and improve density. Mowing grass **frequently** in the fall will also mulch down fallen leaves and prevent smothering of turfgrasses.

Pest management

Turfgrass pests (weeds, diseases, insects) occur for a reason. It is often related to a weakness in the turfgrass plant or some deficiency in the soil (often related to microbial activity). Identification is the first step in pest management. However, instead of looking how to control the pest immediately, ask instead, “Why is it there?” Most turfgrass pest problems can be controlled by selecting resistant varieties of turfgrass species, following best management practices, and maintaining a healthy, balanced soil. The following information will provide key steps in pest management.

Weed management

Weeds are, by definition, plants out of place. Weeds have a natural tendency to fill in if sun, water and nutrients are available without competition. If there are any positive aspects to consider, weeds do protect the soil from erosion and help to conserve water by shading the soil. Ralph Waldo Emerson wrote that a weed is “a plant whose virtues have not been discovered.” Dandelions are excellent producers of organic matter. Clover is a legume that can fix free nitrogen from the atmosphere and share it with turfgrasses. Clover root systems are extensive and contribute significant amounts of resources to soil organisms.

What makes a plant a weed is the intolerance of a homeowner, turf manager or lawn care operator. Perhaps our preconception of that perfect lawn needs to change and our zero tolerance for weeds should be reconsidered. Consider that most synthetic herbicides

do not provide 100 percent control and that many lawns will receive multiple applications until that goal is reached. Part of developing a sound natural lawn care program may be learning to live with a few weeds.

Several points need to be mentioned when discussing weed control strategies for natural lawn care. Integrated programs that combine these strategies will provide greater weed control success.

- Know that many weeds (annuals) can be controlled easily; however, a lawn maintained naturally or chemically will not be weed free (perennials).
- Combinations of cultural practices (mowing height, overseeding to maintain lawn density, and proper fertilization) can reduce the amount of weeds in your lawn by 80 percent.
- Using a corn gluten-based organic fertilizer can provide sufficient preemergence control of many grassy and broadleaf weeds. Combining a high mowing height and maintaining a high lawn density with the use of corn gluten-based organic fertilizers can eliminate the need for synthetic pre-emergence products (crabgrass preventers) and the possibly of blanket applications of “Weed-n-Feed” products when only a few broadleaf weeds exist.
- After proper identification of weeds in your lawn, it is important to know why that weed is there (Table 6) and not just how to get rid of it. Changes in one or two cultural practices can reduce your potential for specific weed problems.
- Consider using natural weed killers. BurnOut II, for example, is an all-natural, nonselective herbicide made from vinegar and plant oils (including clove oil). These products should be used during the warmer months of the year for better efficacy. Results can be seen in three hours or less. It is 100 percent biodegradable and environmentally safe.
- Some difficult weeds (perennials) may need to be spot treated with a synthetic herbicide such as Trimec or Weed-B-Gon. Be sure to read the entire

Table 6. Common conditions that promote certain weeds.

Conditions	Weeds
Thinned turfgrass	All weeds, especially annuals
Mowing too low	Annual bluegrass, chickweed, crabgrass, plantains, speedwell
Compacted soils	Annual bluegrass, crabgrass, dandelion, goosegrass, pineapple weed, plantain, prostrate knotweed, prostrate spurge, speedwell
Poor drainage	Barnyardgrass, nutsedge, plantains
High nitrogen	Annual bluegrass
Low nitrogen	Black medic, clover (legumes)
Low fertility	Foxtails, henbit
High soil pH	Plantains
Low soil pH	Red sorrel
Excessive surface moisture	Algae, annual bluegrass, moss
Drought conditions	Black medic, crabgrass, goosegrass, prostrate spurge, speedwell, yellow woodsorrel
Shade	Chickweeds, moss, violets
Low calcium	Dandelion

label for use, timing and seeding interval.

- A few weeds, here and there, can be removed mechanically or by hand pulling.

Disease management

Soil biology is an important factor in disease development. Proper pH (6.3 – 6.4) and a good nutrient balance alleviate stress and can make the difference between a turf that resists infection and one that does not. Eliminating other stresses (scalping, drought, etc.) also helps to provide a stronger plant that can resist infection.

Proper nitrogen management is especially important (Table 7). High nitrogen levels increase the susceptibility of cool-season grasses (Kentucky bluegrass, tall fescue, perennial ryegrass, fine fescue and bentgrass) to leaf spot, Rhizoctonia brown patch and Pythium blight. Low nitrogen levels increase turfgrass susceptibility to dollar spot and red thread. Low potassium levels in the soil reduce turfgrass tolerance to high temperatures and drought stress, which can increase the potential of diseases such as summer patch. Low pH is often associated with diseases such as brown patch as well.

Knowledge about soil fertility, as it relates to turfgrass diseases, can help guide an individual in the way to manage a lawn. Also from a disease standpoint, supply enough nitrogen so that proper mowing is required on a weekly basis. Sometimes a light application of a natural fertilizer (0.5 lb nitrogen/1,000 sq. ft.) will produce enough active leaf growth that disease symptoms are no longer visible.

Knowing some of these simple guidelines may alter some of your standard practices of the past with one goal in mind — reduce disease potential. Follow some of the recommended cultural practices listed below for control of specific disease problems.

Table 7. Cultural practices to reduce turfgrass disease potential.

Cultural practice	Turfgrass disease
Select resistant species	Tall fescue favors brown patch; Kentucky bluegrass favors dollar spot, leaf spot, powdery mildew, rust, summer patch; perennial ryegrass favors all diseases
Select resistant varieties	All diseases – (e.g.- tall fescue varieties for brown patch, Kentucky bluegrass varieties for dollar spot, leaf spot, powdery mildew, rust)
Maintain sharp mower blade	All diseases
Raise height of cut	All diseases, specifically important for leaf spot, summer patch
Minimize leaf wetness time	All diseases, specifically important for brown patch, dollar spot, leaf spot, rust
Avoid excess water	Brown patch, leaf spot, pythium
Avoid water stress	Fairy ring, rust, summer patch
Avoid excess nitrogen	Brown patch, leaf spot, powdery mildew, pythium
Avoid low fertility levels	Dollar spot, fairy ring, rust, summer patch

Compost tea:

Compost tea has been used for centuries to enhance plant performance, but it has been only recently that its strong disease suppression characteristics have been recognized. Most of the organisms delivered to plant leaf surfaces by compost tea will parasitize, antagonize or steal food from disease organisms to the point that they can no longer compete. Tea that infiltrates into the soil will protect plant roots in much the same way. With the addition of specific components, compost teas can also reduce insect problems (see below). Making effective tea does require as much attention and care as making good quality compost. Tea made from poorly made compost will not have the strong disease suppression characteristics.

To make compost tea, fill a five-gallon bucket or trash container with water, and let this sit for at least 24 hours. Place 2 cups of good-quality compost (earthworm castings, homemade compost, city compost, etc.) in a fine-mesh bag (e.g., socks or pantyhose). Tie a knot and place the bag with the compost into the bucket. Place the bucket outside in the sun for two to three days, and stir two to three times per day. After this period of infusion, you have a great product for foliar feeding of your plants. After making the tea, you can add molasses, sugar, liquid seaweed or garlic (Mosquito Barrier). Place the wet compost from the bag around any plants that need feeding.

Now apply the tea using a watering can or Ortho-Dial-N-Spray applicator. Set the dial on the 6-8 ounce setting and apply to all plants in your landscape. Tea can be applied to leaves, bark or soil. It is best to apply tea from 6 to 9 a.m. Tea can be applied weekly or as needed, but each batch must be use within about 24 hours.

Insect management

Well over 90 percent of the world's arthropods have a neutral or beneficial effect on human activities. In turf, that percentage is even higher; only a few insects cause significant economic damage to our turfgrasses. A recurring theme throughout this publication is the need for a balanced soil and healthy plants. Healthy turf and plants can tolerate higher numbers of damaging insects or simply outgrow whatever damage is incurred. There is ample evidence that healthy soil initiates a chain reaction of biological, physical and chemical phenomena that effectively control many damaging insects or at least limit the amount of damage they can cause.

Insects and other invertebrate pests that damage turf generally fall into one of four categories: root feeders, stem burrowers, sucking-type insects and leaf eaters. Root feeders include white grubs, ground pearls, nematodes and mole crickets. Insects such as billbugs and annual bluegrass weevils burrow in stems and often damage the crown. Chinch bugs, greenbugs,

mites, mealybugs, and spittlebugs are important juice suckers, and the leaf eaters include armyworms, cutworms, sod webworms, and other turf-eating caterpillars. Almost all of these insects are most damaging to turf during the immature stage (larva or nymph) of their life cycle.

When insect problems develop, our first reaction is often to identify the pest and spray an insecticide. We need to realize, however, that these insecticides can also eradicate many beneficial organisms. Use of insecticides can have a detrimental effect on earthworms and saprophytic organisms (soil microbes that feed on organic matter) that typically aid in the decomposition of thatch. This can happen when homeowners apply insecticides for grub control thinking they will eliminate their mole problems. Although this treatment does decrease the activity of moles, it is because their primary food source (earthworms) is depleted.

Excessive amounts of thatch can also weaken or stress the turf and inhibit infiltration of water and nutrients into the root zone. Excess thatch, more prevalent in Kentucky bluegrass and zoysiagrass, can provide habitat for many insects, such as chinch bugs, billbugs, cutworms and webworms. Thatch should be controlled as needed.

Various botanical and biological products offer effective control, but timing is as important in their use as it is with conventional insecticides. Proper identification of the insect and knowledge of its life cycle are keys to effective control. Nearly all insect pests have natural enemies, and care should be taken to protect these natural resources (Table 8).

Table 8. Botanical and biological controls for certain turfgrass insects.

Insect	Control
Armyworms	Endophyte-enhanced turfgrasses, neem, <i>Bacillus thuringiensis</i> bacterium, <i>Steinerema</i> sp. nematodes
Billbugs	Neem
Chinch bugs	Flood area with water, neem
Cutworms	Endophytes, <i>Bacillus thuringiensis</i> bacterium, <i>Steinerema</i> sp. nematodes
Sod webworms	Endophyte enhanced turfgrasses, flood area with water and mild detergents, neem, <i>Bacillus thuringiensis</i> bacterium, <i>Steinerema</i> sp. nematodes
White grubs	<i>Beauveria bassiana</i> fungus, neem, garlic juice, capsaicin extracts, cedar oil, milky spore disease by <i>Bacillus popilliae</i> or <i>Bacillus lentimorbus</i> , <i>Steinerema</i> sp. nematodes, <i>Heterorhabditis</i> sp. nematodes

Mole management

While most people have never seen a mole, they are well aware of the damage moles cause to lawns and flowerbeds. Moles live most of their life underground and are highly specialized animals for their subterranean way of life. Their fleshy snout serves as a highly

sensitive organ of touch and smell to seek out numerous food sources. They possess well-developed claws that have a specialized bone attached to the wrist, which aids in digging. Moles construct networks of feeding tunnels in the soil surface. Many of these tunnels are built after rains when moles are in search of new food sources. Digging of surface tunnels normally proceeds at a rate of 1 foot per minute and they tend to feed and rest on two-hour cycles, 24 hours a day. This part of their daily activity is what makes trapping and baiting so successful.

Trapping is still one of the most efficient means of controlling moles. Success relies on following a few simple steps. If you have the network of shallow tunnels used for feeding, then you can do some effective trapping. First, you need to locate active feeding runways. Second, select a trap to place on this runway. There are several types of traps to choose from. Follow the instructions of the manufacturer to set the trap. The Nash trap (wire hoop type) and the Victor "Out O' Sight" trap (scissors type) are effective but can be difficult to set. The Victor "Harpoon or Gig" type trap has been the most successful trap in use at the MU Turfgrass Research Facility.

Identifying active tunnels: With a small stick or broom handle, poke holes through the top of various tunnels around the network of mole tunnels. Holes that are plugged within two or three hours will indicate which runways are active feeding tunnels at that time. These are the tunnels where you want to set traps or place baits.

Most products available to homeowners through nurseries and garden centers work as repellants and are based on castor bean oil as the active ingredient. Many have been tested on the eastern mole and appear effective on that species, which is the predominant species in Missouri. These products need to be sprayed (garden hose-end applicator) or applied as granules (through a spreader) at regular intervals to maintain a barrier that repels these small mammals. The repellant-type products are marketed as natural and safe, but information about effectiveness is mixed. Mole-Med may have changed its name to Chase due to new ownership and is available in both liquid and granular form. Other repellants include Scoot Mole, Shotgun Mole & Gopher Repellant, Mole Max, Mole-Out, Whole Control and Schultz Garden Safe Mole Repellant.

More recent products include several baits that seem to be effective if applied properly to **active** feeding runways. **Wear rubber gloves whenever handling and placing baits in tunnels.**

Two products called "Kaput Mole Control" (Lesco) and "Moletox Baited Gel" (Bonide) are water-based gels containing warfarin (0.025%) as the active ingredient and flavored like their primary food, earthworms. They are both packaged in syringe-type applicators with which to inject the bait into the tunnels.

The latest mole bait registered is “Talpirid” (Bell Laboratories), a bromethalin-based product that looks, feels and reportedly tastes like earthworms (20 worm-like baits per box). It is the only mole bait that has submitted efficacy studies to the Environmental Protection Agency. MOTOMCO Mole Killer is a bait similar to Talpirid, but in a more affordable package of eight worms.

A granular bait is “Mole Patrol Bait.” Mole Patrol is a ready-to-use, pelletized bait highly palatable with unique attractants. This product contains chlorophacinone, a historically sound anticoagulant of the rodenticide industry. Some studies indicate 100 percent control of moles.

Natural lawn care in a nutshell

Natural lawn care does not provide instant results. Think long-term (several years) instead of short-term care.

Natural lawn care is not just about using natural products or organic fertilizers. It becomes an annual process and not just a list of individual lawn care events. Over time, we are building and promoting a balanced soil of organic matter and a healthy population of soil microorganisms while following good cultural practices to promote healthy plants.

Natural lawn care, like any lawn care program, is not perfect. It may take a little extra effort to pull a weed from time to time or to use a synthetic herbicide to spot treat broadleaf weeds. This may be a small price to pay for the satisfaction of knowing that your lawn is being maintained naturally, responsibly and in an environmentally sound manner.

“Keeping It Simple” is the best approach to natural lawn care. It does not require a large product inventory to maintain a lawn. Following best management practices while incorporating a few key lawn care products is all it takes.

Measuring your lawn and testing the soil are the first pieces of information you need to know about any lawn. Then simply follow good cultural practices — mowing, fertilizing, watering and overseeding. Applying minerals once in the spring or fall with three applications of organic fertilizers (some containing corn gluten) will provide a good natural lawn. Other beneficial products can be added based on a soil test or as dictated by your lawn.

Protecting surface and groundwater quality is a serious environmental issue. Following a natural lawn care program is one way that homeowners, lawn care operators and professional turfgrass managers can protect the groundwater and improve their environmental stewardship.

More information online

Natural Organic Lawn Care for Ohio. Jane C. Martin, Alyn Eickholt, and Joanne Dole. Extension Fact Sheet HYG-4031-04. 2001. Ohio State University.
ohioline.osu.edu/hyg-fact/4000/4031.html

Nonchemical Alternatives for the Home Lawn. David D. Minner, Beth Mankowski, Donald R. Lewis, and Mark Gleason. Horticulture Guide PM1680. 1996. Iowa State University.
extension.iastate.edu/Publications/PM1680.pdf

“Show-Me Yards & Neighborhoods.” City of Columbia, Missouri.
gocolumbiamo.com/PublicWorks/StormWater/show_me_yards.php

“Show-Me Yards & Neighborhoods.” City of Springfield, Missouri.
springfieldmo.gov/community/SMYN/index.html